

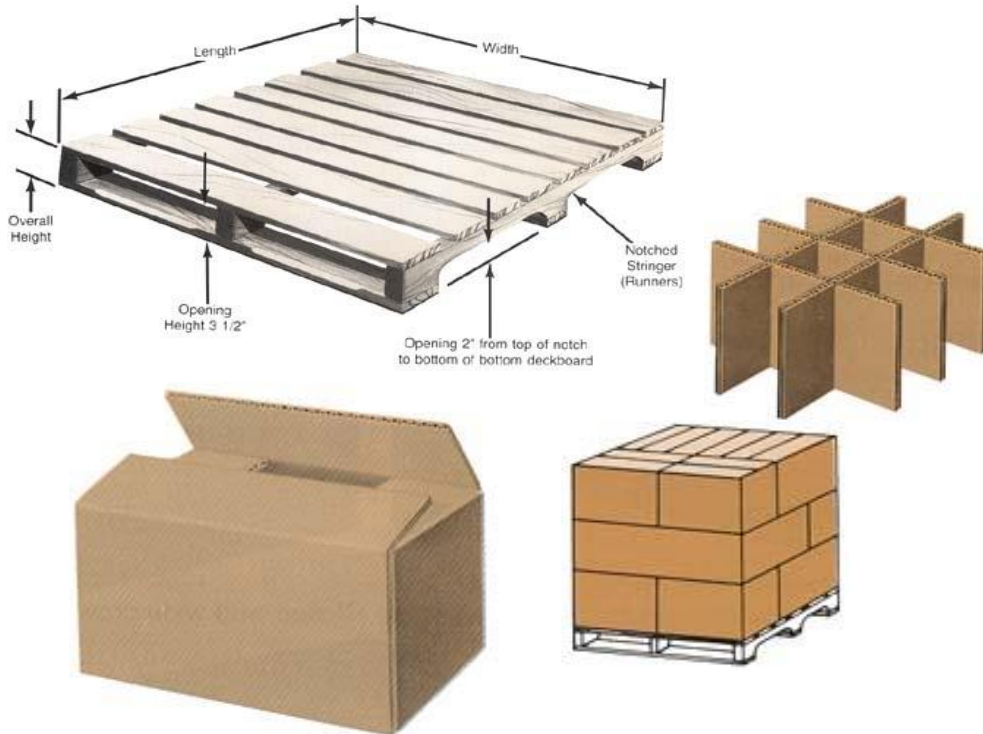

Dayco -Springdale Supplier Packaging Guide



Dayco
1351 Stewart Place
Springdale, AR 72764-1364
479-756-7500
Fax: 479-756-7591

Table Of Contents

1.0	OVERVIEW	2
2.0	EXPENDABLE PACKAGING	4
	CHOOSING A CONTAINER	4
	<i>Manually handled container</i>	4
	<i>Bulk Pack Containers</i>	4
	<i>Container Strength</i>	4
	PART ORIENTATION & PROTECTION	4
	INTERNAL DIVIDERS	5
	LABELING/PARTS IDENTIFICATION.....	5
	PALLETIZATION.....	5
	PROBLEMS.....	8
3.0	RETURNABLE PACKAGING	9
	CONTAINER SIZE	9
	PART ORIENTATION & PROTECTION	9
	INTERNAL DIVIDERS	9
	PALLETIZATION.....	9
	RETURNABLE CONTAINER LABELING	9
	CONTAINER IDENTIFICATION	9
	RE-ORDERING RETURNABLE PACKAGING	10
	PROBLEMS.....	10
4.0	LABELING/PARTS IDENTIFICATION	11
5.0	EXAMPLES	111
6.0	DAYCO CONTACT INFORMATION	18

1.0 Overview

The following are the basic requirements that each supplier must adhere to in developing and using expendable packaging, returnable containers, and identification methods. Whenever quoting new parts, use this guide to determine packaging requirements. Quotes must include costs for packaging independent from the piece part price. Separate costs into three sections: Piece part price only, packaging material cost per piece, and packaging labor cost per piece. All three of these should add up to the total cost per piece.

Each supplier must adequately plan for packaging in advance. All suppliers must utilize packaging methods that insure their products arrive and can be handled at our facility in the same quality condition in which they were manufactured. Their products must be packaged in containers that meet the needs of our consumption process at the most economical price. Improving our competitive position in the world market does not allow for defective parts due to manufacturing, packaging or shipping methods.

The shipping system must be designed to accomplish many goals. It must:

- ❖ Contain and protect the production parts
- ❖ Provide for safe and economical packing and unpacking
- ❖ Help reduce inventory requirements
- ❖ Promote efficient part access for the operator
- ❖ Allow workspace flexibility
- ❖ Minimize operator walk time
- ❖ Provide for efficient and ergonomically acceptable manual and/or mechanical handling
- ❖ Provide for effective use of plant space, highway trailers and railcars for the lowest overall system cost
- ❖ Provide for responsible final disposition of packing materials by maximizing recycling and minimizing disposal

All conflicts with exceptions to, or request for, deviation from these packaging requirements must be approved by Dayco Products.

Suppliers will pack, label and ship in compliance with the requirements of common carriers. All of Dayco Products packaging specifications conform to the Automotive Industry Action Group (AIAG) packaging guidelines. All features/surfaces considered critical to the quality or operation of the part (e.g., fragile, painted, or machined surface, etc.) are to be protected from damage, contamination and/or sediment from rust, dirt, moisture, wood chips, or other debris.

Packaging should be quoted in expendable packaging unless Dayco Products specifically requests returnable packaging. Suppliers that currently ship parts to Dayco Products via returnable containers should quote new parts in returnable packaging as long as they are similar to parts already shipping in returnable packaging. For example, if you ship plastic pulleys in returnable packaging now, you should assume returnable packaging for new plastic pulleys being quoted.

At the end of this guide, you will find examples of parts and the packaging they should be shipped in, as well as contact information in case of problems or questions that may arise regarding packaging.

2.0 Expendable Packaging

Choosing a Container

Container selection should adapt to each specific situation, depending on the type of part. This packaging manual was designed to ensure that each supplier's packaging will be optimal for the entire material flow process from supplier through user.

Manually handled container

All incoming parts should be shipped in manually handled containers weighing less than 35 lbs when full. The containers need to maintain their integrity from the supplier to the destination. Improperly sized containers or partially filled containers tend to be damaged during shipment. The ideal size for a manually handled container is:

12 X 12 X 12 - For aluminum castings. Aluminum castings should be open-topped containers.

12 X 15 X 12 - Small plastic parts such as bushings, except for parts packed into returnable containers.

9 X 9 X 4 minimum to 10 X 10 X 5 maximum (or ¼ keg cartons) - For bolts, washers, and dust covers (Note – Cartons must be under 6" to fit on our lines).

10 X 10 X 5 minimum to 12 X 15 X 6 maximum - For steel and powdered metal pulleys depending on weight and volume.

10 X 10 X 5 minimum to 12 X 15 X 12 maximum - For pulleys depending on weight and volume.

These container sizes are to ensure that the containers will fit onto our flow racks and production lines.

Bulk Pack Containers

Unless otherwise directed, use bulk pack containers for Springs. Also, use bulk containers for raw pulley shells (pulley shells without bearings), and any odd shaped or large aluminum casting that do not fit well into a manually handled container. There may be some special parts in which Dayco will ask to be shipped in bulk containers due to certain restrictions on the production lines.

Bulk pack container sizes should be sized accordingly to the 32 X 30 or a 45 X 48 wood pallet footprint.

Container Strength

Both manually handled and bulk pack containers should be constructed with adequate strength to protect the parts.

Part Orientation & Protection

Parts should be oriented and packaged for maximum protection. Parts separation or layer packing should be utilized for parts with critical surfaces such as:

- ❖ Steel pulleys with e-coated surfaces
- ❖ Ribbed pulleys (both steel and plastic)

❖ Aluminum castings with machined surfaces

These type of parts should never be shipped in bulk, meaning they are not to be dumped into a carton with no layers separation or row dividers. If shipped in a manually handled container or a bulk pack container, these parts should be layer packed or cell divided.

All pulleys are to utilize layer separation, meaning there is to be a divider between each tier of parts in a carton.

Internal Dividers

Internal cardboard dividers should be used when necessary to protect delicate surfaces of parts.

Labeling/Parts Identification

Labeling should concur with the AIAG and Dayco labeling standard. Please refer to section 4.0 in this manual for labeling requirements.

Palletization

Dayco Standard size pallets are 45 X 48, 32 X 30, and 48 X 40 footprints. Pallets are to be 4-way entry compatible. Use the following specifications for each of the three pallet designs:

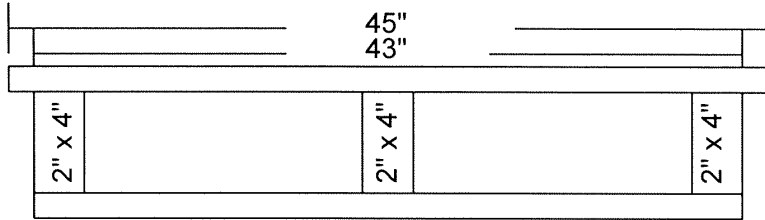
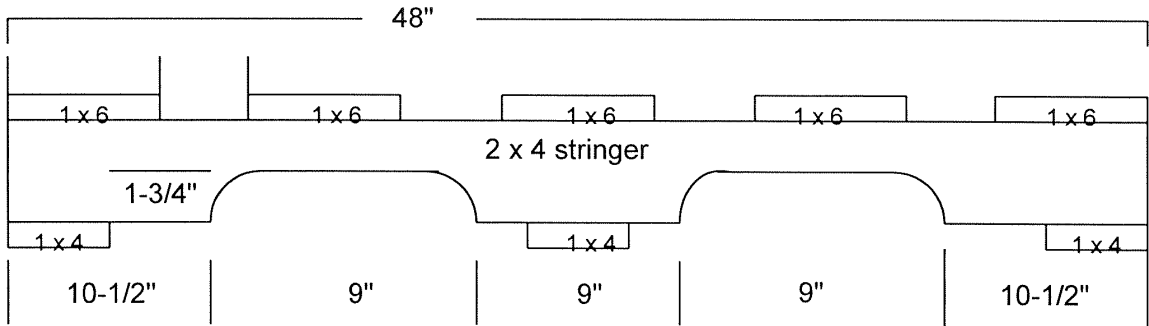

Dayco Products

N-2 pallet

48" x 45" wood pallet

1219 mm x 1143 mm

Drawing date: 5/17/99

Revision 1

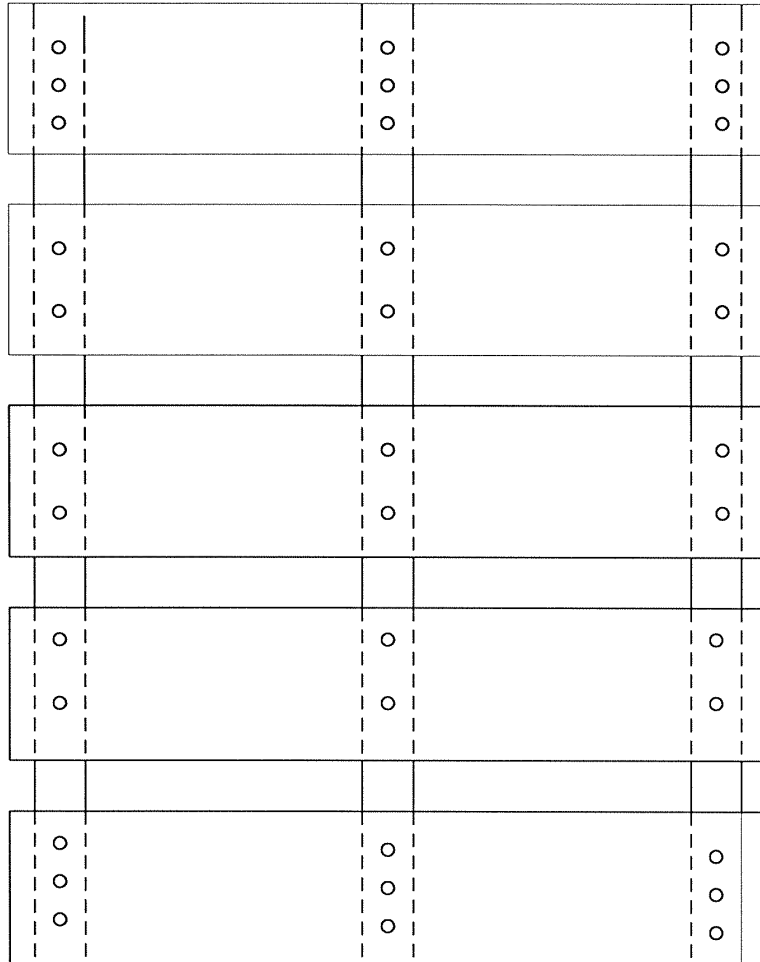

- Top deck = 5 ea.
- 1 x 6 x 45" Oak (1/2" min. thickness)
- Notched Stringers = 3 ea.
- 2 x 4 x 45" Oak or yellow pine (nominal)
- bottom Tie Strips = 3 ea.
- 1 x 4 x 43" Oak (1/2" min. thickness)

Secure joints with senco "0.25 BAB staples or its equivalent or, #80 pallet screw nails: 3 fasteners per joint in tip deck outer boards. Two fasteners per joint in tip deck inner boards, two fasteners per joint in bottom tie strand

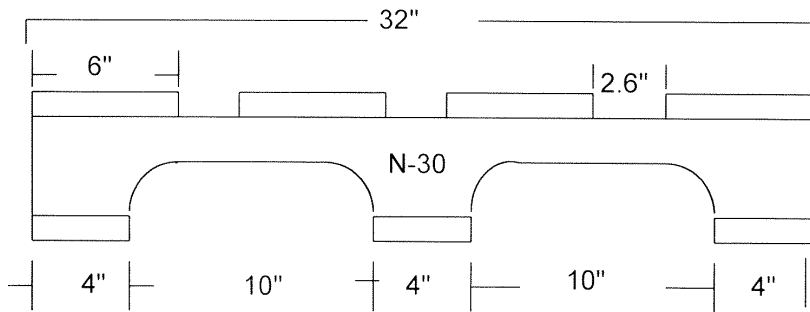

Dayco Products
N-30 pallet
 Drawing date : 4/13/99
 Revision 1

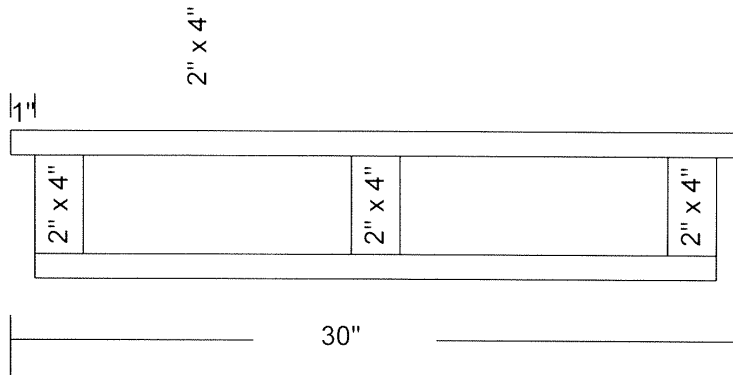

Top deck= 4 each
 1 x 6 x 30" Oak(1/2" min. thickness)
 Notched stringers = 3 ea.
 2 x 4 x 32" Oak or yellow pine(nominal)
 Bottom tie strips= 3 ea.
 1 x 4 x 28" Oak or yellow pine(nominal)

N-30 Stensiled on both sides of pallet for identification in plant
 2" high lettering

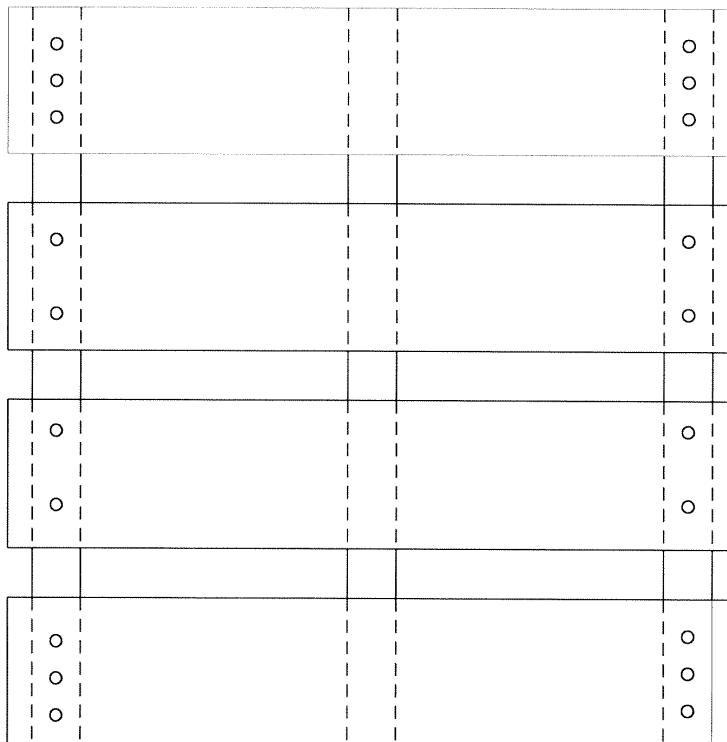

Secure joints with senco "0.25 BAB staples or its equivalent or, #80 pallet screw nails: 3 fasteners per joint in top deck outer boards. Two fasteners per joint in tip deck inner boards, two fasteners per joint in bottom tie strand

file: n-30
 e:\user\dan moore\visio\n-30

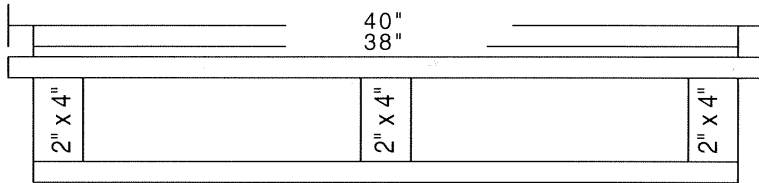
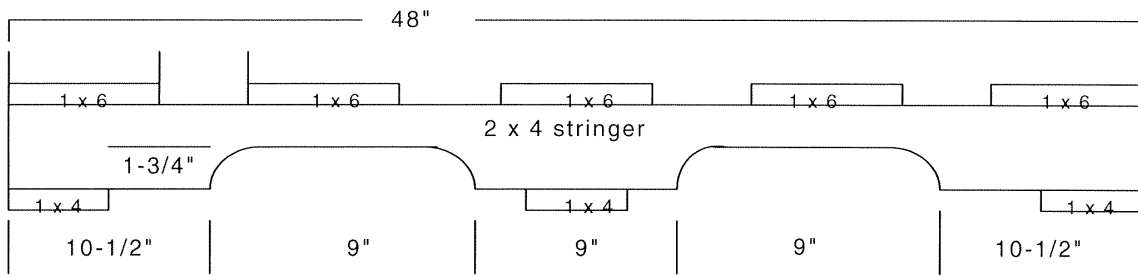

Dayco Products
N-9 pallet
 48" x 40" wood pallet
 1219 mm x 1016 mm
 Drawing date: 10/1/99
 Revision 1.0

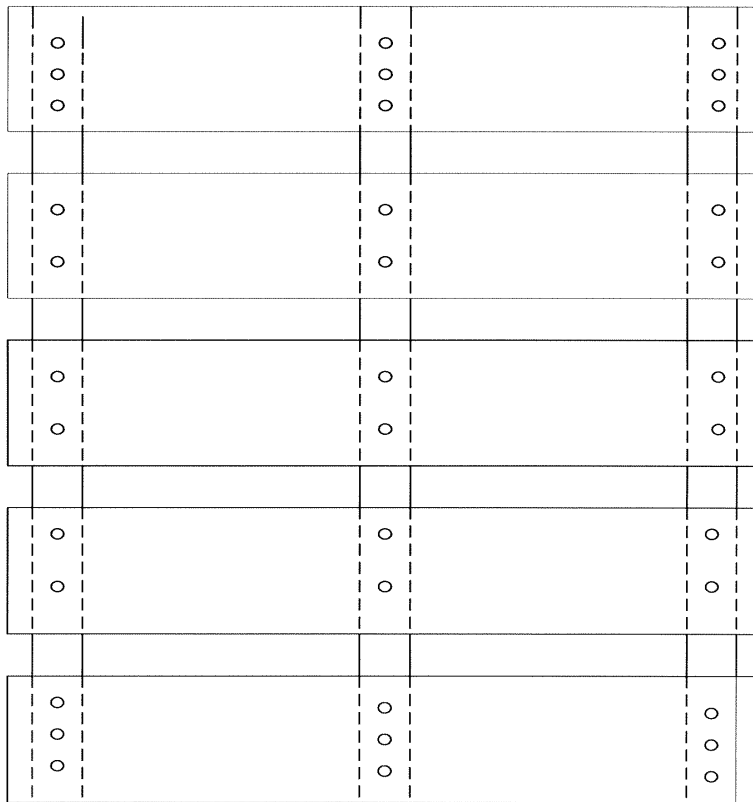

Top deck = 5 ea.
 1 x 6 x 40" Oak (1/2" min. thickness)
 Notched Stringers = 3 ea.
 2 x 4 x 40" Oak or yellow pine (nominal)
 bottom Tie Strips = 3 ea.
 1 x 4 x 38" Oak (1/2" min. thickness)

Secure joints with senco "0.25
 BAB staples or its equivalent or,
 #80 pallet screw nails: 3
 fasteners per joint in top deck
 outer boards. Two fasteners per
 joint in top deck inner boards,
 two fasteners per joint in bottom
 tie strand

software: viso
 file: e:\user\danmoore\visio\n-9

Problems

Any concerns or problems that may occur with packaging scenarios should be discussed with Dayco Products.

3.0 Returnable Packaging

Container Size

Standard sized containers are to be used with all incoming Dayco parts. Dayco will choose the container and pallet combination to use with a particular product.

Weight Restrictions – Manually handled returnable containers should weigh less than 35 lbs.

Part Orientation & Protection

It is very important that the parts are protected in the returnable containers. With either returnable dunnage or expendable cardboard dunnage, the parts should maintain their integrity until they reach their destination. For plastic pulleys, it is acceptable to stack them in rows with a row divider separator needed for ribbed pulleys. Part orientation should allow for maximum container occupancy while staying under the weight limit and providing adequate part protection. It is sufficient for small plastic parts to be “bulk packed” into the manually handled container. Some of these parts are required to be shipped in plastic bags inside the container. Aluminum castings do not need to be layered with layer separators as long as there are no machined surfaces on the casting that could get damaged. If machined surfaces exist, the castings need to be layer packed or separated with other dunnage. All pulleys should use layer separators. Refer to section 2 for more information about Part Orientation & Protection. Many of the same expendable packaging rules apply to returnable packaging.

Internal Dividers

Internal cardboard dividers or returnable dividers should be used when necessary to protect delicate surfaces of parts. Generally, there are layer pads and row dividers that are used with Dayco returnable containers. In some instances, returnable cell trays are used. If expendable dunnage is to be used, Dayco will return all internal dunnage with the empty containers to be used again by the supplier as many times as possible.

Palletization

Dayco Products returnable containers are modularized so that most all the container sizes will fit on the same size pallet. Containers are to be palletized onto the pallet with the container labels facing outward. Use the included top cap and seat belt assemblies to secure the pallet load. In some instances, if there is a shortage of top caps or lids, or if there is no seat belt assembly with the pallet load, the supplier should wrap the pallet securely with stretch wrap.

Returnable Container Labeling

The manually handled returnable containers should have a label placed on only one end of the container in the label placard designated spot. Refer to section 4.0 for Dayco labeling standards.

Container Identification

The pallets and lids/top caps will have Dayco Products identification marks designating them as property of Dayco Products. Only use the containers, pallets, lids, topcaps, and dunnage for Dayco parts.

Re-ordering Returnable Packaging

Suppliers are expected to manage their inventories to assure that returnables are always available for shipping. Only under emergency conditions may suppliers ship in disposable containers once returnables have been implemented. If you are low on returnable packaging, please contact Dayco Products. Most likely more containers are on the way. Dayco uses a very liberal approach to determining the number of containers allotted to the supplier.

Problems

If the supplier has any problems, questions, or concerns about returnable containers, please contact Dayco Products. See section 6 for Dayco Contact Information.

4.0 Labeling/Parts Identification

Please see the Dayco barcode labeling specifications.

5.0 Examples

This section gives examples of current supplier packaging and outlines what should be used for packaging.



The pictures above show some different examples of how Dayco identifies the containers and pallets. While most are hot stamped with the information, some use labels and plaques to identify the container or pallet.



The pictures above show how both returnable containers and expendable packaging is presented to our production lines. It is important to ship in a Dayco approved container size so the pack can be used throughout the Dayco facility.



Some suppliers are required to ship small plastic parts such as bushings in plastic bags. The bags are then returned to the supplier for re-use with the empty container as shown in the photo on the left.

The next pictures show some examples of some plastic pulleys packed into returnable containers.



The photo above on the left shows a ribbed plastic pulley packed into a returnable container. The vertical row dividers separate each pulley's ribbed surface from being damaged. Notice also that there are two extra pulleys packed on the end of the container at 90 degrees to take up the extra slack in the container. The photo above and to the right shows a flat edge plastic pulley layer packed with 21 parts per layer. No row dividers are needed here since these pulleys do not have ribs.



The two photos above also show plastic pulleys in returnable containers. Notice that the photo on the left shows flat edge pulleys placed in rows of 8. No vertical row dividers are needed since these pulleys have no ribs. The photo on the right shows ribbed plastic pulleys that do need row dividers to protect the ribbed edges. Note that the photos show just the first layer in the container. Most all containers will have multiple layers separated by horizontal layer dividers.



Notice the photo on the left shows returnable containers palletized in the Dayco racking system. The labels are placed to the outside so they can be easily identified.



Springs are to be sent bulk in an expendable bulk pack as shown above. Dayco will then “decant” them into smaller plastic totes as shown that are to be used throughout the Dayco facility.

The following photos show examples of parts that should be sent in expendable packaging.



The two photos above show aluminum castings in manually handled cardboard cartons. The cartons should be open-topped as shown. The cartons in the photo on the left are a 12" X 12" X 12". This is the ideal size for aluminum castings. The photo on the right uses a 12" X 15" X 12". This is also acceptable as long as the weight is less than 35 lbs.



The two photos above show the Palletization layout for manually handled cartons that feature open-tops. Note that the open-topped containers should be palletized with a common lid for layer separation. The pallet load should be wrapped or banded securely for part protection as shown.



If the aluminum castings have machined surfaces, they should be divided or layer packed. In the three photos above, the one on the far left does not have any critical surfaces, so it can be “bulk packed” into the small carton. The photo in the middle has parts with machined surfaces so they are cell packed. The photo on the right shows parts that also have machined surfaces. They are layer packed and laid out in a uniform manner.



The above photo shows raw pulley shells. Raw pulley shells have a pre-operation in the Dayco facility and have to be handled prior to going to the production line. It is recommended that raw pulley shells be shipped in an expendable “bulk pack” in order to minimize packaging costs. Notice that they are layer packed.



The two pictures above show small plastic parts that are shipped in expendable containers. The photo on the left shows very small slot plugs that are packed into a small carton. These parts require no dividers. The parts on the right are also small plastic parts packed into small manually handled cartons.



The photo above and on the left shows light-weight metal bushings. This packaging is sufficient since the parts do not weigh much and will not get damaged when packed bulk into a small carton. The carton on the right shows an example of how bolts should be shipped. This is a 1/4 keg carton.



The photos above have machined surfaces and need to be layer packed as shown. These are larger sized parts that do not fit well in manually handled containers.

6.0 Dayco Contact Information

Dayco
1351 Stewart Place
Springdale, AR 72764-1364
479-756-7500
Fax: 479-756-7591

Plant Manager
Doug Moye – 479-756-7508

Logistics/Materials Manager
Jim Jones – 479-756-7530

Buyers
Angie Steiner – 479-756-7535
Erick Whitten – 479-756-7533

Commodity Manager
Jim Snyder – 479-756-7506

Supplier Development Engineer
Don Brown – 479-756-7552

Production Manager
Sammy Townsend – 479-756-7519

Continuous Improvement Manager
Industrial Engineer
Safety & Environmental manager
Dan Moore – 479-756-7571

Additional Contacts – I. T.
Ron Michaels – 479-756-7504

Contact for new quotes: Jim Snyder

Existing Suppliers should contact their buyer for questions or concerns

Questions about this manual or part packaging please contact: Dan Moore